

LA BREA AIR, INC.

5601 W. SLAUSON AVENUE SUITE 262, CULVER CITY, CA 90230

PHONE: (310)258-9100 FAX : (310)258-9110 www.labrearentals.com

TO:

ATTENTION:

PAGE: OF

FAX :

PH:

FROM:

DATE:

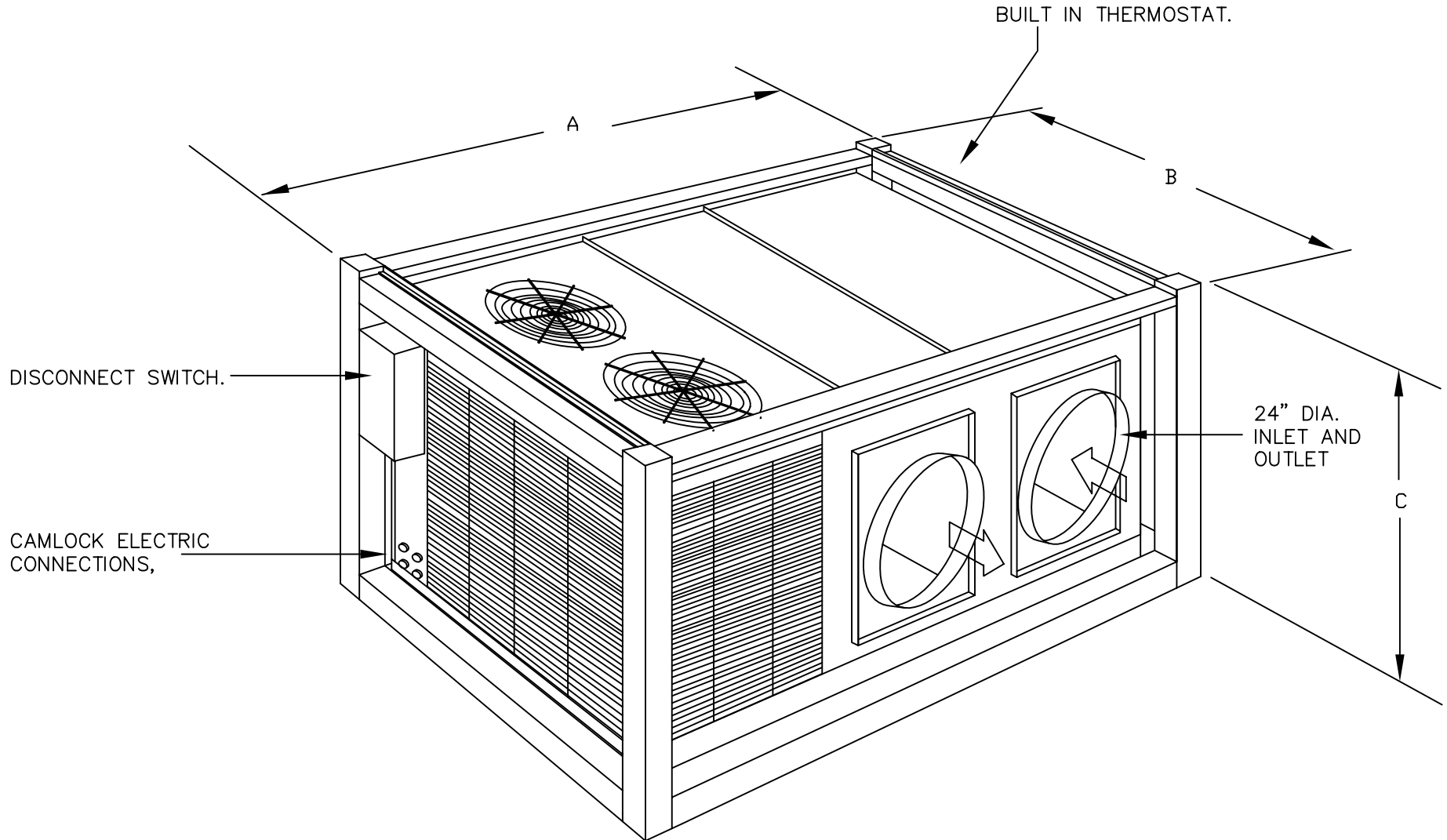

protoA1:1

| UNIT/CAPACITY     | DIMENSIONS |        |       |   |   |   |                | AMPERAGE |        | NOTES:                                                                                                                                                                         |
|-------------------|------------|--------|-------|---|---|---|----------------|----------|--------|--------------------------------------------------------------------------------------------------------------------------------------------------------------------------------|
|                   |            |        |       |   |   |   |                | CLG.     | HTG    |                                                                                                                                                                                |
| ACP-25T           | A          | B      | C     | D | E | F | APPROX. WEIGHT | 480      | V-3 PH | 24"Ø FLEX DUCT IN 25' LENGTHS<br>POWER CABLE @ 100'<br>THIS UNIT IS EQUIPPED WITH THERMOSTAT<br>ON-OFF SWITCH AND RED LIGHT CIRCUIT<br>*54 KW (183,000 BTU/H) HEATING CAPACITY |
| MFG.: AMERICAN S. | 11'-0"     | 7'-11" | 5'-5" |   |   |   | 3500#          | 60       | *85    |                                                                                                                                                                                |